

Waffle Coulters (4) with Crumbler:
Additional tillage in tougher soils.



Rubber Tire Press Wheels with Waffle Coulters (2) and Roller:
Close slot, minimum till and firm the soil.



*OVER 35 YEARS OF
DEPENDABLE EQUIPMENT
FOR PROGRESSIVE FARMING*

NEW!

RIP STRIP OPTIONS

GENERATION II



**1 1/4" Auto Reset
on the go Shank
(Optional 3/4"
shanks) with
Waffle Coulters (4)
and 20" rollers**

**3/4" or 1-1/4"
Shear Bolt Shank
Waffle Coulters (2)
with Crumbler:**
Minimum tillage in
sandy, loamy soils.





The smart approach to conservation tillage!

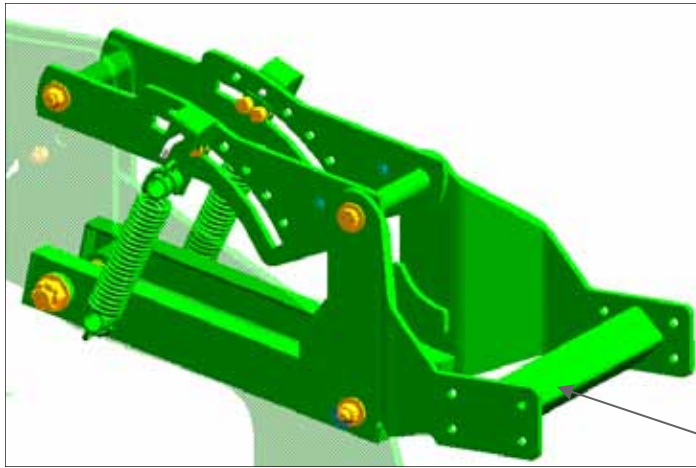

Ensures uniform seed bed preparation throughout a wide range of operating depths with virtually no adjustment.

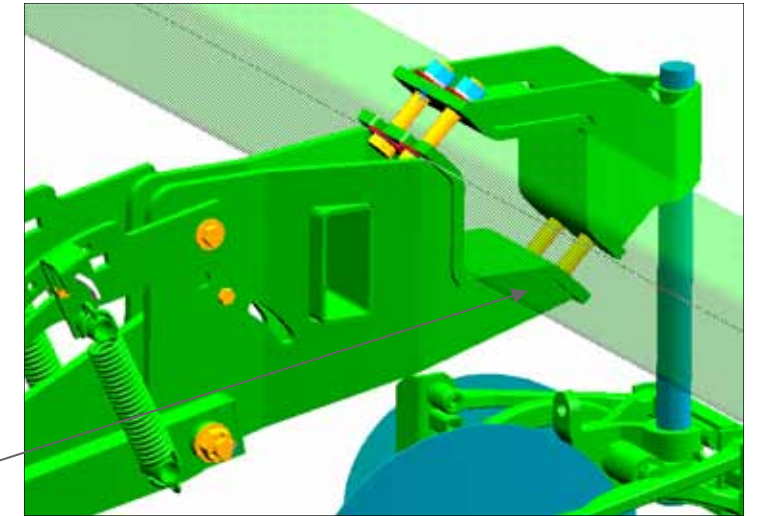

The 7" diamond-mount bracket clamp promotes superior stability.

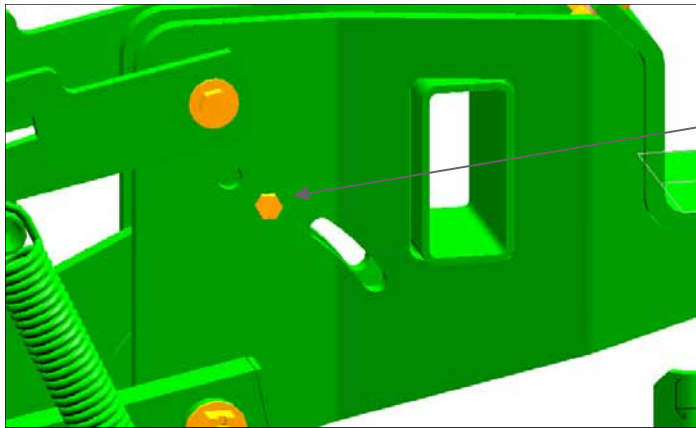

Location of shearbolt makes replacement quick & easy.

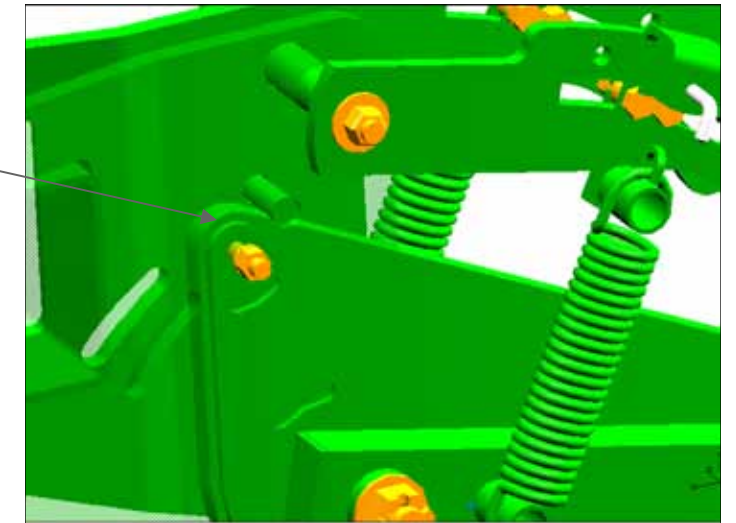

Shank is forced into position after tripping, making shear bolt replacement safe and effortless.



Accommodated many secondary tillage options, including new heavy-duty rubber press wheels proven to minimize shank blow-out.

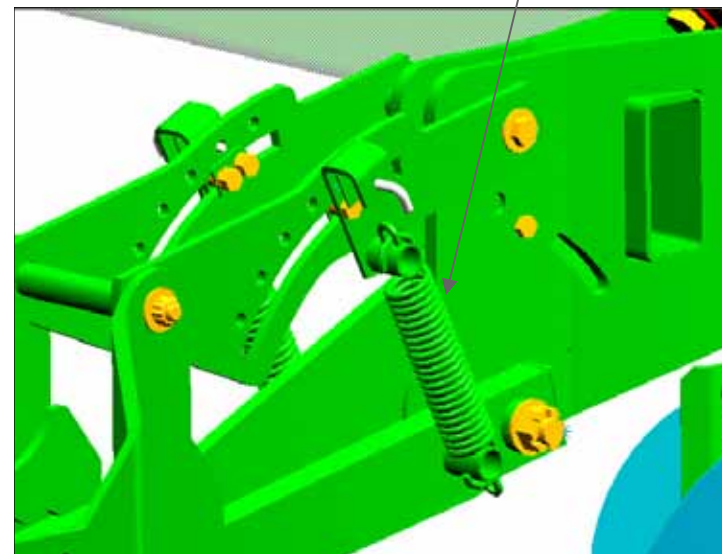

The dual spring down-pressure mechanism allows for up to 550 lbs of added weight transferred to the tillage components for improved tillage in various soil conditions.

Shank options include both 3/4" and 1 1/4" thick versions to maximize performance in varying soil types and conditions.

