



47-SERIES

**4700, 4750, 4755 & 4760
DISC MOWER CADDY**

OPERATOR'S MANUAL



THIS MANUAL TO ACCOMPANY MACHINE

**PART NO. 47-OM-01
PRINTING DATE: MAY 2019**

1-YEAR WARRANTY POLICY

KELLEY MANUFACTURING COMPANY (KMC) warrants that Disc Mower Caddies sold to the original purchaser shall be free of any defects in material and workmanship if used under normal operating conditions. The warranty period begins on the date of purchase by the retail customer and ends twelve (12) months thereafter. KMC's sole responsibility is to repair and/or replace the defective part or parts at no cost to purchaser. This remedy is the **SOLE AND EXCLUSIVE REMEDY** of purchaser.

The purchaser must fill out and return the warranty registration form found in the front of the operator's manual. Failure to return the warranty registration form within 30 days shall result in the goods being sold "AS IS", and all warranties shall be excluded.

1. This warranty shall not apply to those items that are by nature worn in normal service.
2. Items such as tires, bearings, wheel hubs, hydraulic cylinders, drivelines and all other items warranted by the original manufacturer are warranted only to the extent of their individual manufacturer warranty, and KMC is not warranting any of the said items.
3. Warranty shall not apply for any damage caused by foreign objects that enter the disc mower caddy.
4. Warranty shall not apply for any damage caused by improper lubrication or lack of service.
5. Warranty shall not apply for any damage resulting from transport of the disc mower caddy after delivery by the dealer.
6. All warranty claims must be made through a KMC licensed dealer, and a warranty form request must be submitted to KMC within 30 days of failure of the warranty provision shall be unenforceable against KMC.

No agent or person has authority to change or add to this warranty as written.

THE ABOVE IS THE ONLY WARRANTY MADE BY KMC AND IS MADE EXPRESSLY IN LIEU OF ALL OTHER WARRANTIES, EXPRESSED OR IMPLIED. KMC MAKES NO WARRANTY OF MERCHANTABILITY AS TO ANY GOODS MANUFACTURED BY KMC AND FURTHER, KMC DOES NOT WARRANT ANY SUCH GOODS AS SUITABLE FOR ANY PARTICULAR PURPOSE TO THE RETAIL CUSTOMER. THE SUITABILITY OF GOODS FOR ANY PURPOSE PARTICULAR TO THE CUSTOMER IS FOR THE CUSTOMER, IN HIS SOLE JUDGEMENT, TO DETERMINE. KMC FURTHER MAKES NO WARRANTIES WITH RESPECT TO ITS MANUFACTURED GOODS THAT WOULD NORMALLY BE DISCLOSED BY AN EXAMINATION. THIS IS THE FULL AND FINAL EXPRESSION OF ALL WARRANTY LIABILITY OF KMC. NO OTHER WARRANTY, EITHER EXPRESSED OR IMPLIED, SHALL BE ENFORCEABLE AGAINST KMC.

Kelley Manufacturing Co.

80 Vernon Drive / Zip 31794 P.O. Drawer 1467 / Zip 31793 Tifton, GA

DISC MOWER CADDY OWNERS MANUAL

Table of Contents:

FORWARD

Introduction	2
To the Purchaser	2
Models Covered in This Owner's Manual	3
Pre-Operational Check List	4

SAFETY

Symbol Information	5
Safety Decals	6
Retail Customers Responsibility under the KMC Warranty	7
Safety Procedures	7-8

ASSEMBLY SET-UP

General	9-12
Overhead Layouts	13-17
Drawbar Position	18
Implement Hitch	18
Mower Driveline	19
Positioning of Mower on Caddy	19
Attaching Mower	20-23
Adjusting Angle of Mower	23
Miscellaneous	23
Before Operation	24

OPERATIONAL SET-UP

Tractor Preparation	
Front End Preparation	25
Horse Power Requirements	26
Sway Blocks	26
Drawbar Position	26

MAINTENANCE

FORWARD

INTRODUCTION:

The **KMC Disc Mower Caddy** is designed to provide long life to the components of the caddy and mower by providing smooth, consistent power, whether the tractor is turning or running straight forward. Optional lift kits are available for some mowers. Also optional 300 pound weight can be added to the side of the mower to give additional counter balance and to improve stability with bigger Disc Mowers Models.

TO THE PURCHASER

This **KMC Disc Mower Caddy** has been carefully designed and manufactured to give years of dependable service. In order to operate it efficiently and maintain it properly, please read the instructions within this manual thoroughly.

Some components of this machine are labeled left or right. The notations are determined by standing behind the implement and facing the direction of forward travel.

After reading this Operator's Manual, Please keep it for reference each season.

To insure procurement of the proper repair parts, please record your machine's Model Number, Serial Number, and Purchase Date as shown below:

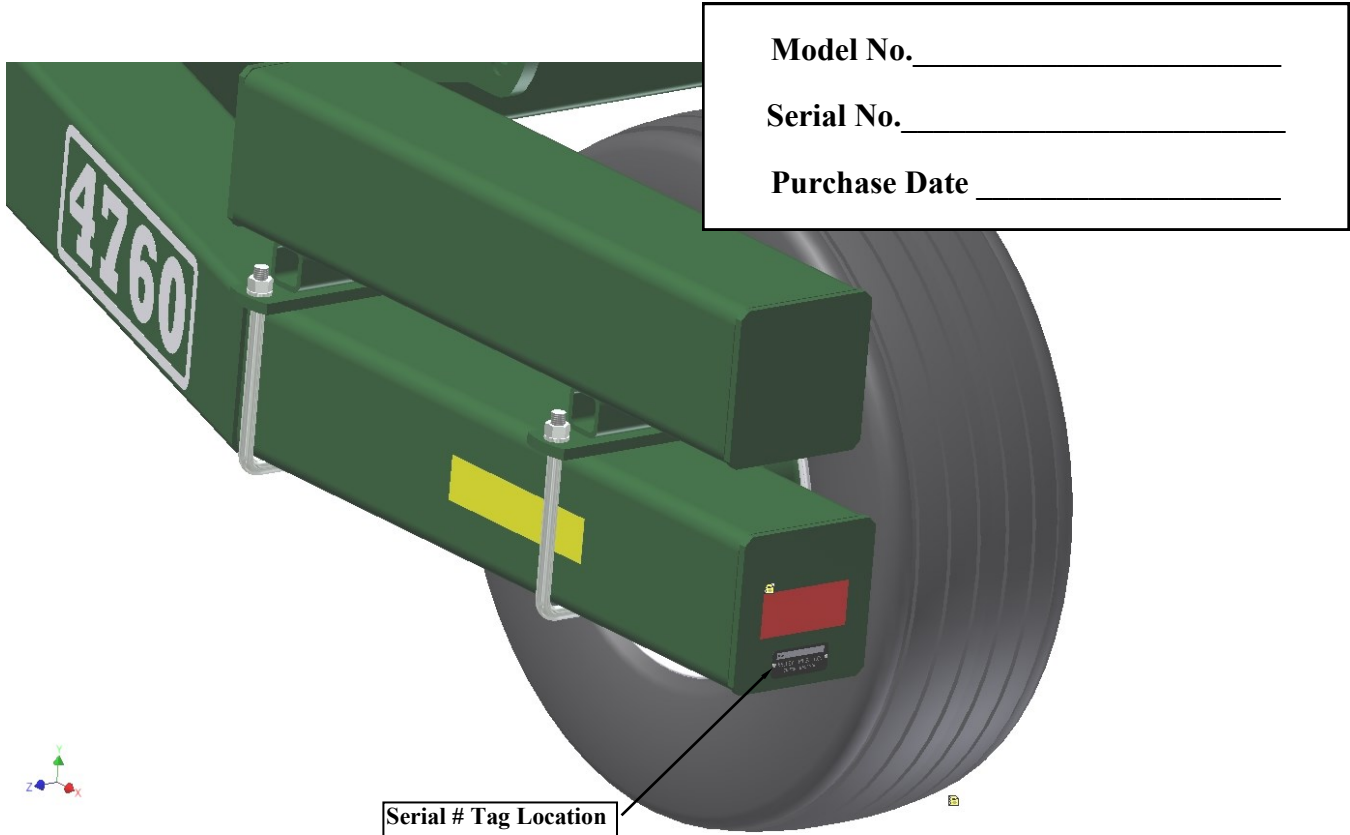

MODELS COVERED IN THIS OWNER'S MANUAL:

**(MODEL 4700SH)
MOWER CADDY
WITHOUT LIFT KIT**

**(MODEL 4750SH)
MOWER CADDY
WITHOUT LIFT KIT**

**(MODEL 4700LK)
MOWER CADDY
WITH LIFT KIT**

**(MODEL 4750LK)
MOWER CADDY
WITH LIFT KIT**



**(MODEL 4755SH)
MOWER CADDY
WITHOUT LIFT KIT**

**(MODEL 4755LK)
MOWER CADDY
WITH LIFT KIT**

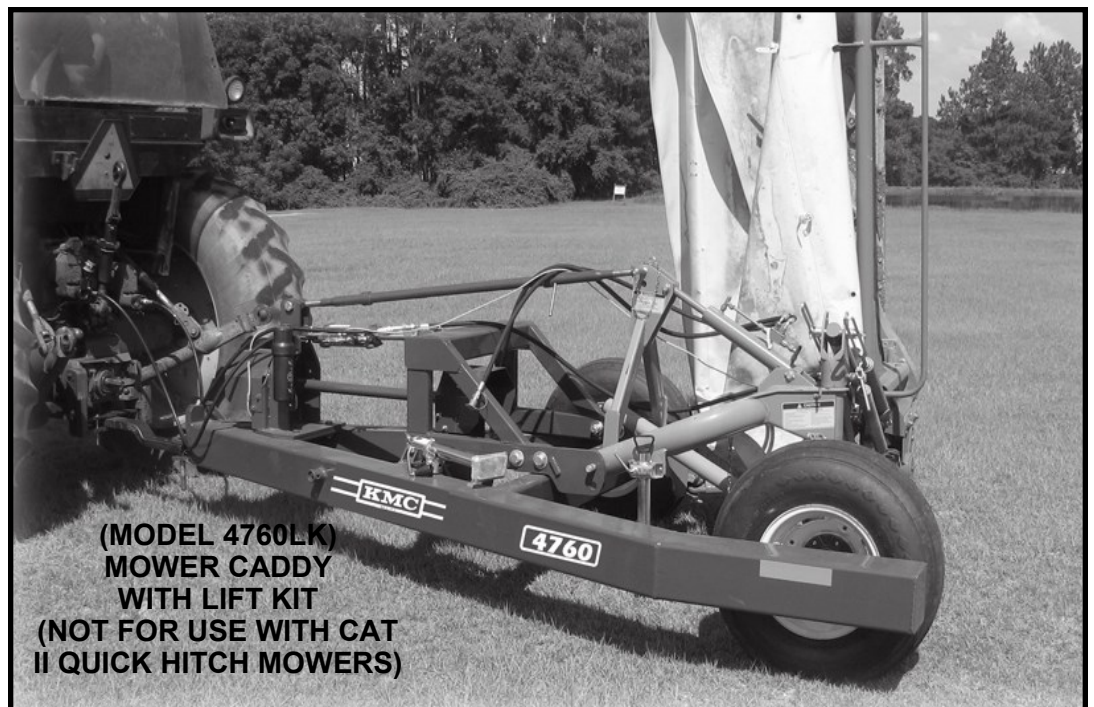

**(MODEL 4760SH)
MOWER CADDY
WITHOUT LIFT KIT**

**(MODEL 4760LK)
MOWER CADDY
WITH LIFT KIT
(NOT FOR USE WITH CAT
II QUICK HITCH MOWERS)**

PRE-OPERATIONAL CHECKLIST:

- All safety and operating procedures reviewed
- All hardware checked for tightness
- Hitch connection to implement information reviewed
- Field adjustment procedures reviewed
- Lubrication information reviewed
- Machine fully lubricated
- Warranty information reviewed

SAFETY

SYMBOL INFORMATION



This safety alert symbol is used throughout this manual to identify safety messages. When you see this symbol, read the message which follows as it will advise you of possible injury.

REMEMBER

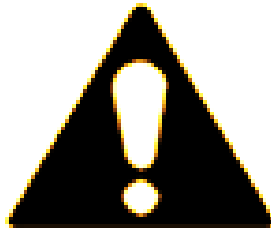

THINK SAFETY!



(RED)

This symbol indicates an imminently hazardous situation that, if not avoided, will result in death or serious injury.



(ORANGE)

This symbol indicates a potentially hazardous situation that, if not avoided, could result in death or serious injury. It may also be used to alert against unsafe practices.



(YELLOW)

This symbol indicates a potentially hazardous situation that, if not avoided, may result in minor or moderate injury. It may also be used to alert against unsafe practices.





**(GREEN
OR
BLACK)**

Is used for instruction on operating, adjusting, or servicing a machine.

SAFETY DECALS

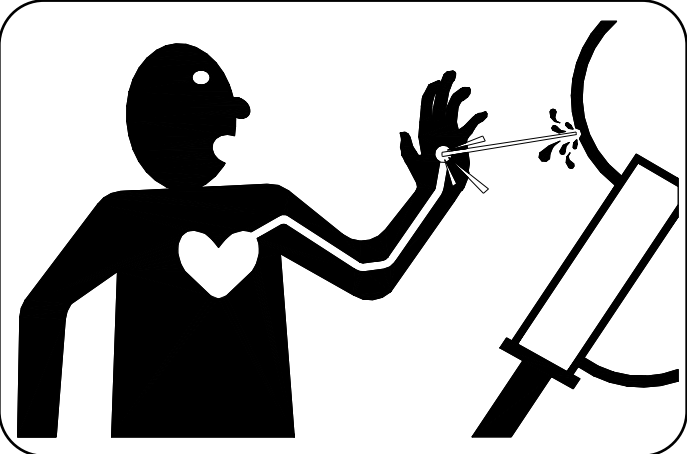
The Safety decals that follow are associated with the implement covered in this owner's manual. They should be reviewed and associated with where they are applicable on the implement being covered.







WARNING

DO NOT GO NEAR LEAKS

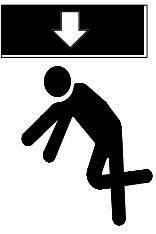
- High pressure oil easily punctures skin causing serious injury, gangrene or death.
- If injured, seek emergency medical help. Immediate surgery is required to remove oil.
- Do not use finger or skin to check for leaks.
- Lower load or relieve hydraulic pressure before loosening fittings.







DANGER

TO KEEP FROM TIPPING OVER WHILE LIFTING:

- ALWAYS LIFT FRAME WITH FORK THRU LIFT RING.
- MAKE SURE ALL BYSTANDERS STAND CLEAR WHILE LIFTING.

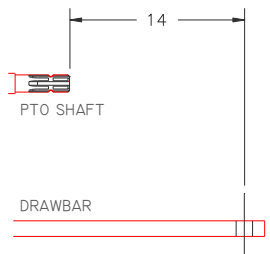
FAILURE TO DO SO COULD RESULT IN SERIOUS INJURY OR DEATH





CAUTION

- SET TRACTOR DRAWBAR POSITION AS SHOWN TO AVOID DAMAGE TO DRIVELINE AND OTHER IMPLEMENT COMPONENTS.



WARNING

1. KEEP ALL SHIELDS IN PLACE.
2. STOP ENGINE BEFORE LEAVING OPERATOR'S POSITION TO ADJUST, LUBRICATE, CLEAN OR UNCLOG MACHINES, UNLESS OTHERWISE SPECIFICALLY RECOMMENDED IN THE "OPERATOR'S MANUAL".
3. WAIT FOR ALL MOVEMENT TO STOP BEFORE SERVICING THE MACHINE.
4. KEEP HANDS, FEET AND CLOTHING AWAY FROM POWER DRIVEN PARTS.
5. KEEP OFF EQUIPMENT UNLESS SEAT OR PLATFORM FOR OPERATION AND OBSERVATION IS PROVIDED.
6. KEEP ALL OTHERS OFF.
7. USE FLASHING WARNING LIGHTS WHEN OPERATING ON HIGHWAYS EXCEPT WHEN PROHIBITED BY LAW.
8. MAKE CERTAIN EVERYONE IS CLEAR OF MACHINE BEFORE STARTING ENGINE OR OPERATION.





WARNING

EXPLOSION HAZARD

SEALED FRAME MEMBERS MAY CONTAIN FLAMMABLE GAS UNDER PRESSURE.

TO PREVENT SERIOUS INJURY OR DEATH, DO NOT DRILL, WELD, OR PENETRATE ANY FRAME MEMBERS OR BALLASTED WEIGHT RACKS WHICH DO NOT HAVE OPEN ENDS.

RETAIL CUSTOMERS RESPONSIBILITY UNDER THE KMC WARRANTY:

The retail customer's responsibilities are:

1. To read the Operator's Manual and operate the **Disc Mower Caddy** in accordance with the instructions given in this manual.,
2. To inspect the **Disc Mower Caddy** daily, lubricate as specified and repair or replace parts as needed, especially when continued use would cause damage or excessive wear to other parts.
3. To maintain and keep in place all safety shields, decals and devices.
4. When warranty service is necessary, it is the customer's responsibility to deliver the machine to the KMC dealer from which it was purchased. Warranty repairs should be submitted to the dealer within **thirty (30)** days of failure.
5. Dealer travel to the machine or hauling the machine to his shop for the purpose of performing warranty service is not allowed under KMC warranty. It is a cost to be paid for by the retail customer. Any arrangement whereby the dealer agrees to absorb all or part of this cost is strictly between the dealer and the retail customer.

SAFETY PROCEDURES:

Safety and performance are the primary objectives of the designers of KMC equipment. Safety features have been incorporated into this machine where possible and warnings given in other areas. For your safety, **PLEASE** read and observe the following safety procedures.

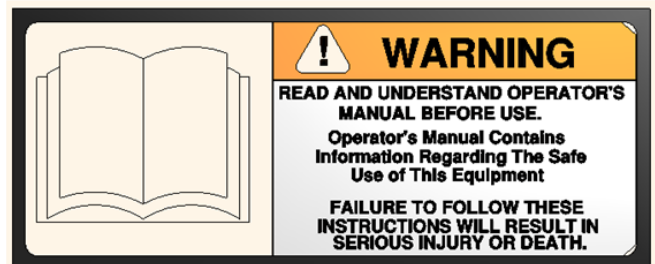

1. All persons operating this piece of equipment should **READ** the owner's manual. **(In addition, the operator's manual & decals on the mower itself warn you of further danger & should be READ & observed closely.)**



2. Do not permit anyone to ride on the machine at any time.



3. Before starting or operating the machine, make a walk-around inspection and check for obvious defects such as loose mounting bolts and damaged components. Correct any deficiencies before starting. **(The equipment must be properly maintained and guarded and must be suitable to performing its task.)**

4. Keep all persons a safe distance away from all sides of the machine while it is in operation.

5. **Do not allow children to operate the Disc Mower Caddy . Only experienced tractor operators should operate the tractor when the Disc Mower Caddy is in use.**



6. Stay clear of hydraulic lines, as they maybe under extreme pressure or heat.

7. Drive safely during transport; excessive speed while turning or on rough ground could cause damage to the **Disc Mower Caddy** and/or cause the tractor to tip over. **(Maximum speed of implement should never exceed 20 mph on highway and 10 mph off-highway.)**

Do **NOT** transport Disc Mower Caddy with optional weight rack mounted unless mower is attached.

8. Make sure hitch components are attached securely before operating or transporting.

9. Use flashing warning lights when on highways, except where prohibited by law.

10. Disengage PTO, apply parking brake, and stop tractor engine before dismounting tractor. Allow mechanisms to stop completely before cleaning, working, or adjusting on machine. Even when the tractor is stationary, you should make sure it is properly secured and made safe by following the **Safe Stop procedure:**

1. **Handbrake/Footbrake on**
2. **Controls in neutral/park**
3. **Engine off**
4. **Key out**



11. Keep hands, feet and clothing away from moving parts.

12. Make sure everyone is clear of machine before starting tractor or operating machine.

13. Observe all safety decals located on machine. Replace them if they become damaged.



HIGH VOLTAGE SAFETY ACT

Georgia Law requires that anyone operating equipment within 10 feet of an overhead high voltage line of more than 750 volts, must contact the Utilities Protection Center (UPC) by telephone at least 72 hours before commencing the work. For more information call (811), toll free (1-800-282-7411) or visit on the web "www.gaupc.com.

Please contact your local power company about laws before operating near high voltage lines.

ASSEMBLY SET-UP

GENERAL:

Throughout this manual we will be discussing various features and components of the KMC Disc Mower Caddy. References to various components for adjustments, settings, performance, and lubrication are made. The following diagram will help in identifying these components.

DISC MOWER CADDY BASIC FEATURES

4760 CADDY (NON-LIFT KIT)

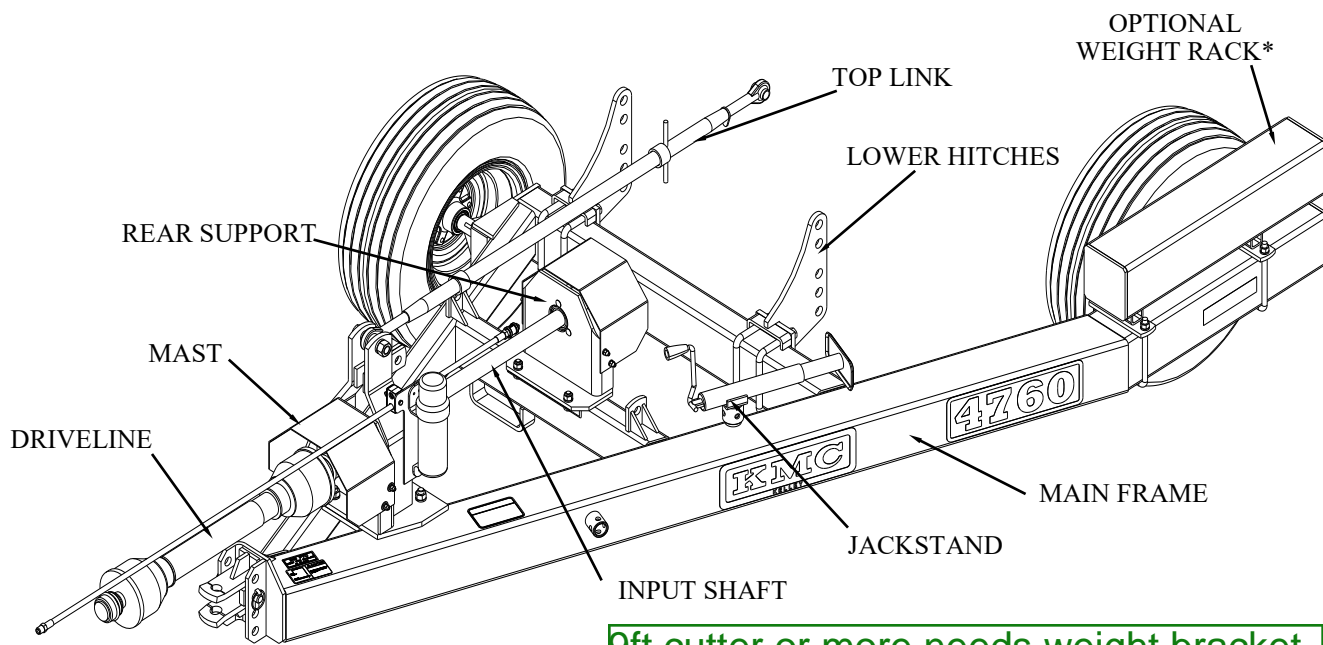

9ft cutter or more needs weight bracket

4760 CADDY (LIFT KIT) (NOT FOR USE WITH CAT II QUICK HITCH MOWERS)

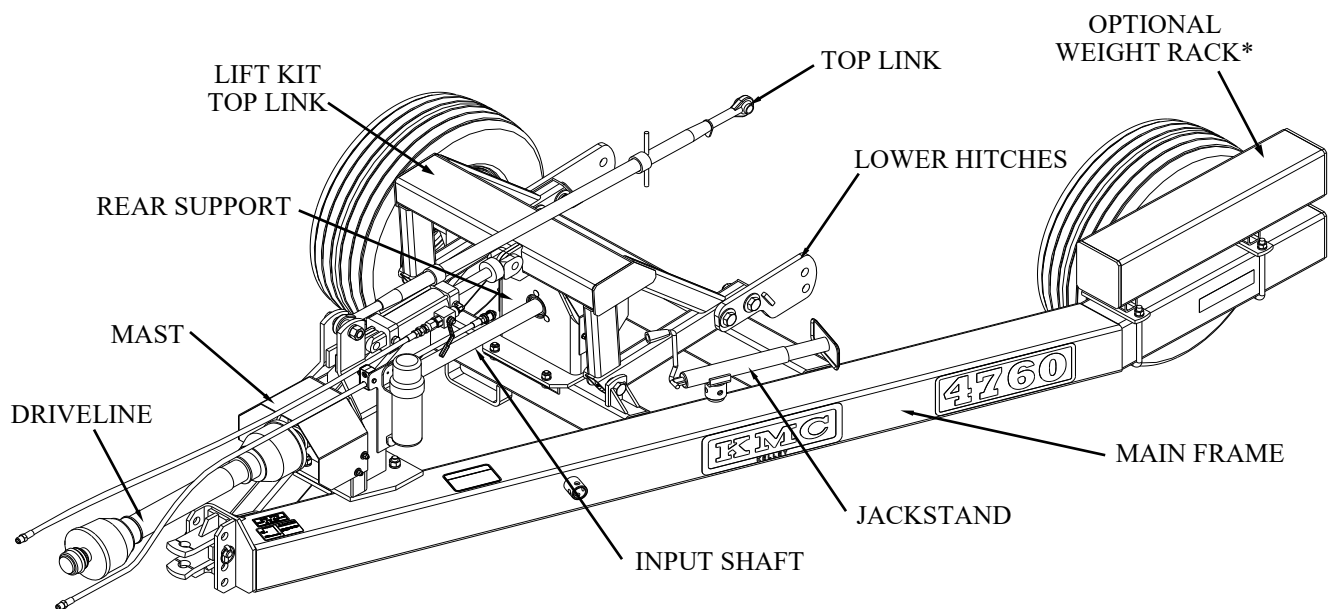

* Do NOT mount weight rack until after mower is attached.



WARNING

CARE SHOULD BE TAKEN DURING SET-UP AND ASSEMBLY OF THIS PRODUCT. DEATH OR SERIOUS INJURY COULD OCCUR IF PROPER STEPS ARE NOT TAKEN TO FULLY SECURE THE UNIT WHEN WORKING UNDERNEATH IT. FOR YOUR SAFETY, ENSURE THE UNIT IS PROPERLY SUPPORTED BY LOWERING THE JACKSTAND SUPPORTS THAT HAVE COME ASSEMBLED WITH IT, OR PROPERLY SECURE THE UNIT WITH ANY HOISTING DEVICES BEFORE ATTEMPTING ANY FURTHER SET-UP OF THIS PRODUCT. ANY HOISTING DEVICES SHOULD BE RATED TO FULLY SUPPORT THE LOAD OF THE UNIT BEING LIFTED.

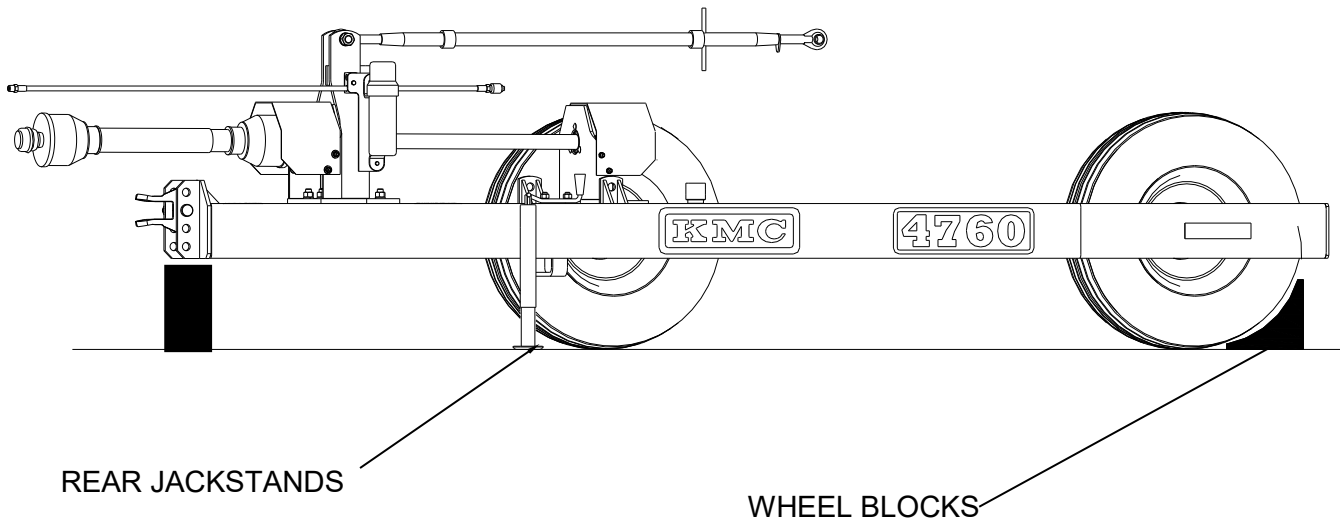

! IMPORTANT !

Before set-up and assembly can be completed ensure that all hardware is in place and fully tightened. Refer to the **Bolt Torque Chart** below for proper torque values.

BOLT TORQUE CHART

SAE GRADE 5



DIAMETER & THREADS PER INCH	TENSILE STRENGTH MIN. PSI	PROOF LOAD LB	CLAMP LOAD LB	TORQUE DRY FT LB	LUBRICATED FT LB
1/4-20	120,000	2,700	2,020	8	6.3
1/4-28	120,000	3,100	2,320	10	7.2
5/16-18	120,000	4,450	3,340	17	13
5/16-24	120,000	4,900	3,700	19	14
3/8-16	120,000	6,600	4,950	30	23
3/8-24	120,000	7,450	5,600	35	25
7/16-14	120,000	9,050	6,780	50	35
7/16 20	120,000	10,100	7,570	55	40
1/2-13	120,000	12,100	9,050	75	55
1/2-20	120,000	13,600	10,200	85	65
9/16-12	120,000	15,500	11,600	110	80
9/16-18	120,000	17,300	12,950	120	90
5/8-11	120,000	19,200	14,400	150	110
5/8-18	120,000	21,800	16,350	170	130
3/4-10	120,000	28,400	21,300	260	200
3/4-16	120,000	31,700	23,780	300	220
7/8-9	120,000	39,300	29,450	430	320
7/8 14	120,000	43,300	32,450	470	350
1-8	120,000	51,500	38,600	640	480
1-14	120,000	57,700	43,300	720	540

SAE GRADE



DIAMETER & THREADS PER INCH	TENSILE STRENGTH MIN. PSI	PROOF LOAD LB	CLAMP LOAD LB	TORQUE DRY FT LB	LUBRICATED FT LB
1/4-20	150,000	3,800	2,850	12	9
1/4-28	150,000	4,350	3,250	14	10
5/16-18	150,000	6,300	4,700	24	18
5/16-24	150,000	6,950	5,200	27	20
3/8-16	150,000	9,300	6,980	45	35
3/8-24	150,000	10,500	7,900	50	35
7/16-14	150,000	12,800	9,550	70	50
7/16 20	150,000	14,200	10,650	80	60
1/2-13	150,000	17,000	12,750	110	80
1/2-20	150,000	19,200	14,400	120	90
9/16-12	150,000	21,800	16,350	150	110
9/16-18	150,000	24,400	18,250	170	130
5/8-11	150,000	27,100	20,350	210	160
5/8-18	150,000	30,700	23,000	240	180
3/4-10	150,000	40,100	30,100	380	280
3/4-16	150,000	44,800	33,500	420	310
7/8-9	150,000	55,400	41,600	600	450
7/8 14	150,000	61,100	45,800	670	500
1-8	150,000	72,700	54,500	910	680
1-14	150,000	81,500	61,100	1,020	760

CADDY SPECIFICATIONS

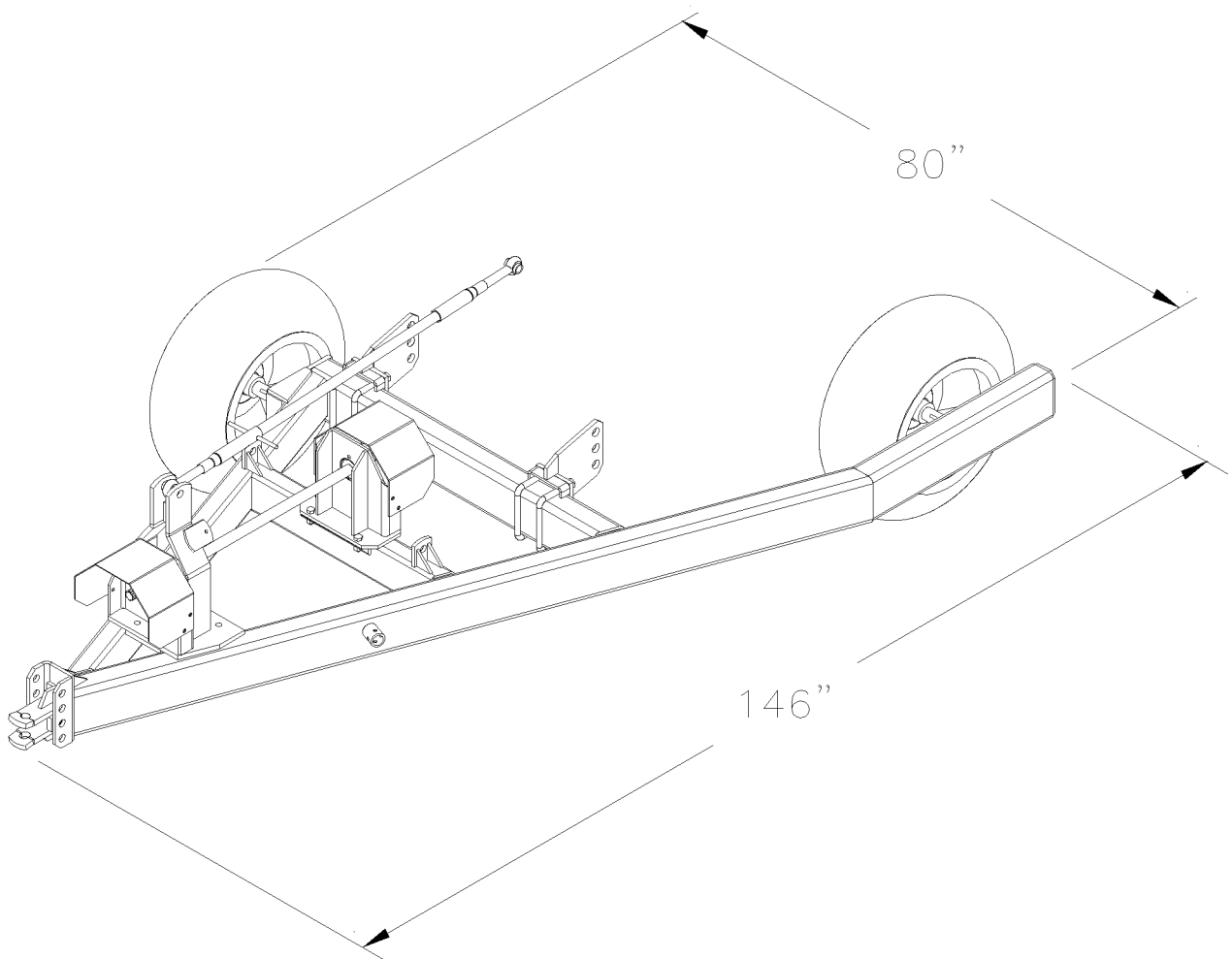

Overall Length - 146 inches

Overall width - 80 inches
85 inches (4760 MODEL)

Weight - 1300 lbs (4700 MODEL)
1400 lbs (4750 MODEL) w/ Lift Kit add 100 Lbs
1500 lbs (4755SH MODEL)
1650 lbs (4755LK MODEL)
1650 lbs (4760SH MODEL)
1750 lbs (4760LK MODEL)
300 lbs (4760 Weight Rack)

Tires - 11L x 15SL

Operating Speed - 540 RPM

Hitch Specifications - Standard Hitch Version: CAT II 3-Point, CAT II Quick Hitch;
Lift Kit Version: CAT II 3-Point **ONLY**

OVERHEAD LAYOUTS:

4700 SERIES

NOTE: The original Model 4700 Caddy used the Mower's Driveline upfront between the tractor and Caddy.

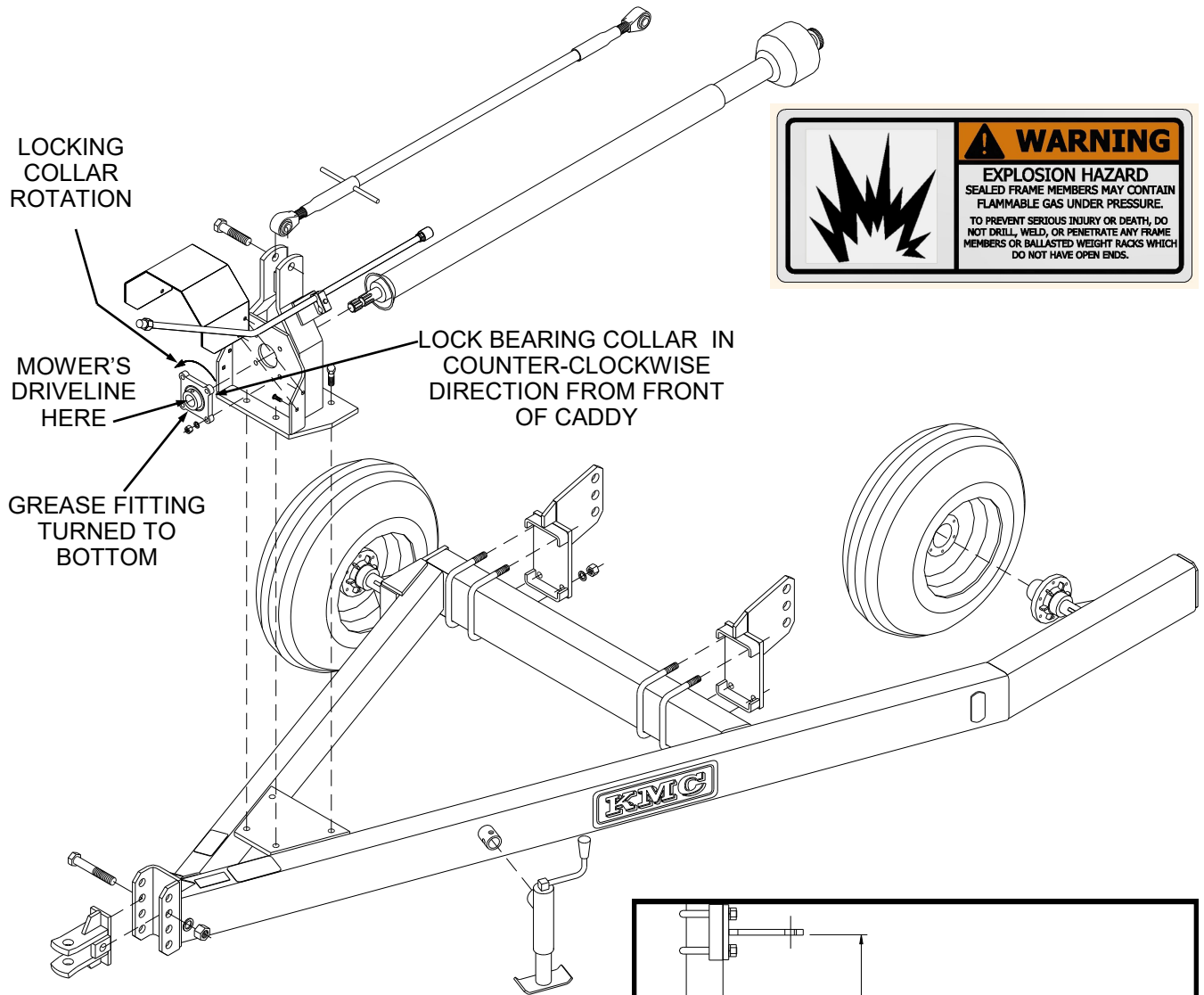

	WARNING
	EXPLOSION HAZARD SEALED FRAME MEMBERS MAY CONTAIN FLAMMABLE GAS UNDER PRESSURE. TO PREVENT SERIOUS INJURY OR DEATH, DO NOT DRILL, WELD, OR PENETRATE ANY FRAME MEMBERS OR BALLASTED WEIGHT RACKS WHICH DO NOT HAVE OPEN ENDS.

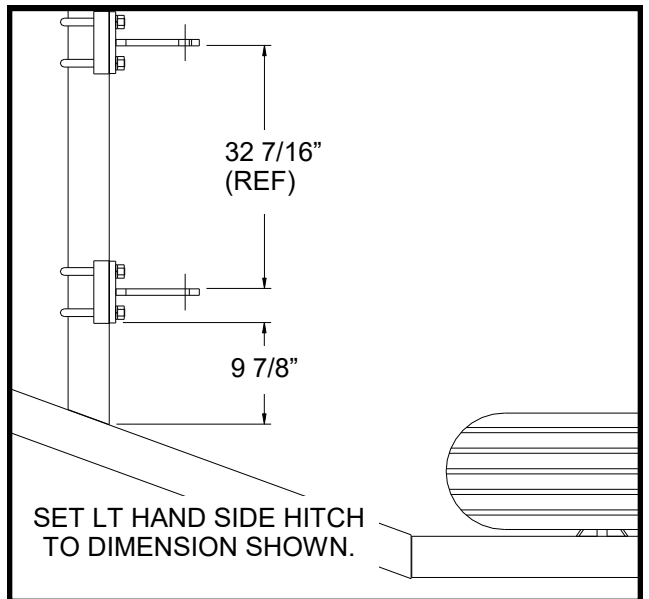

4755LK SERIES

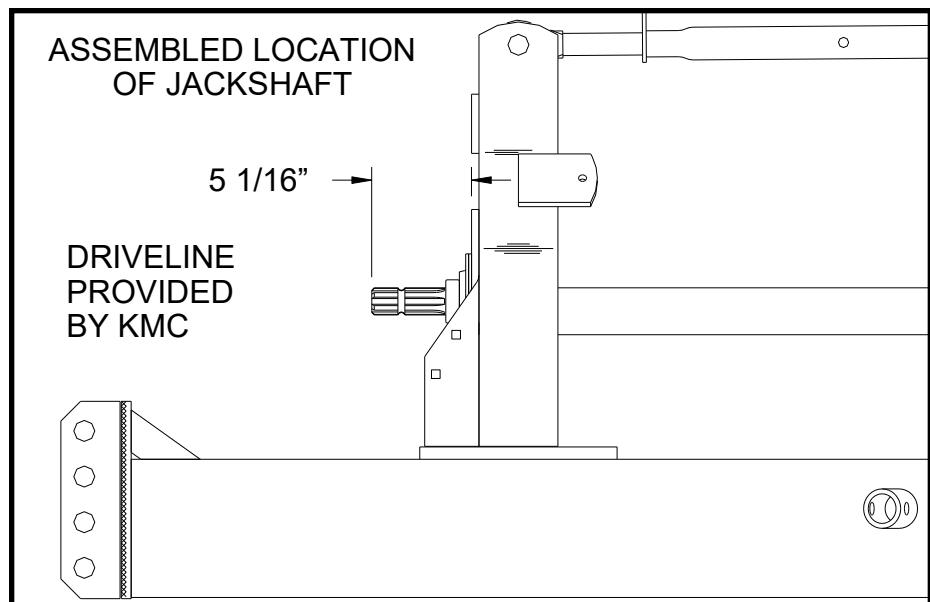
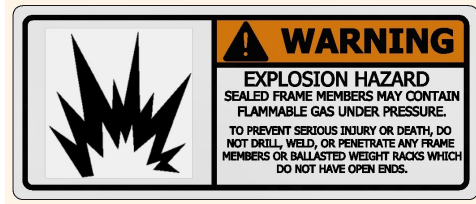
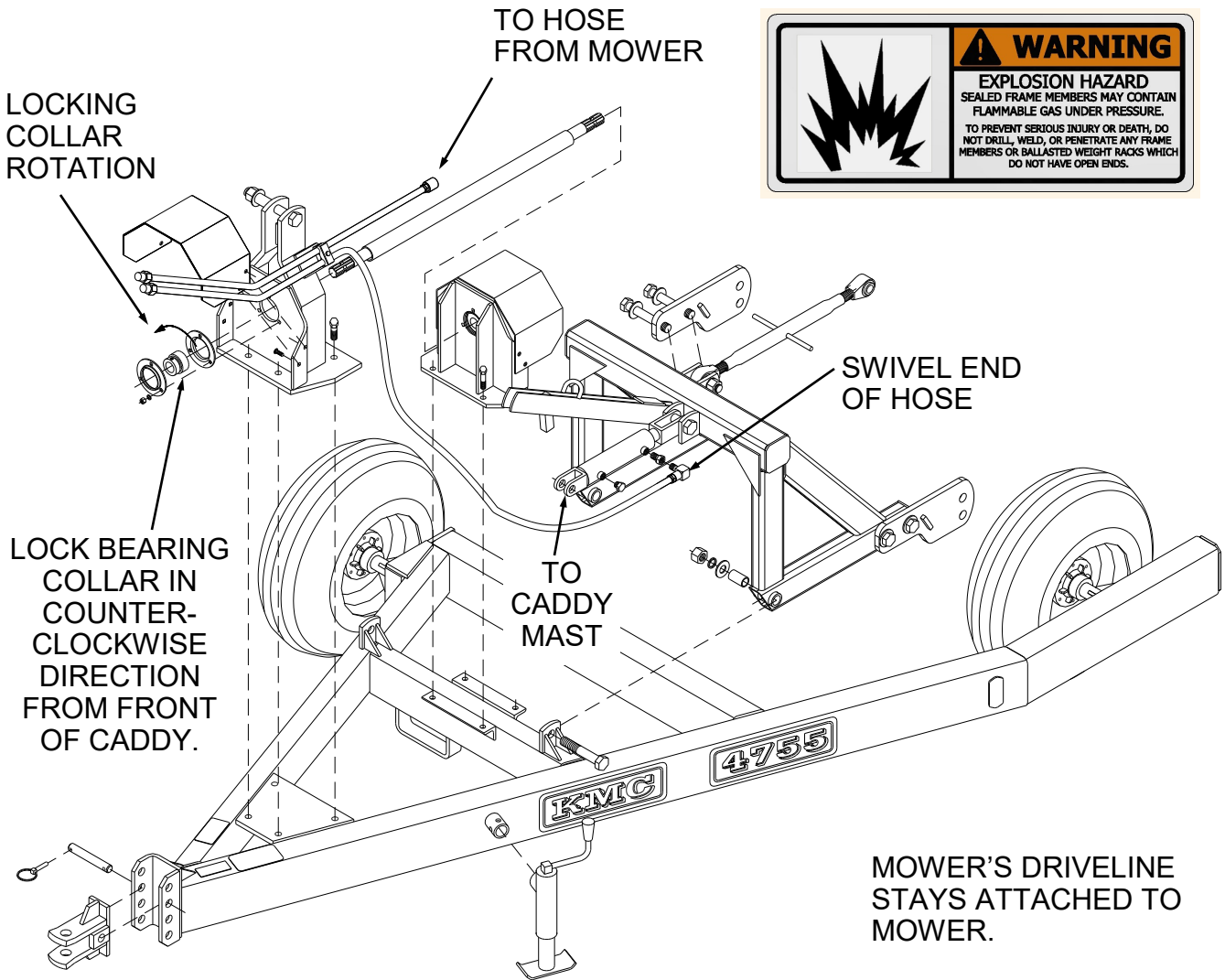

4755SH SERIES

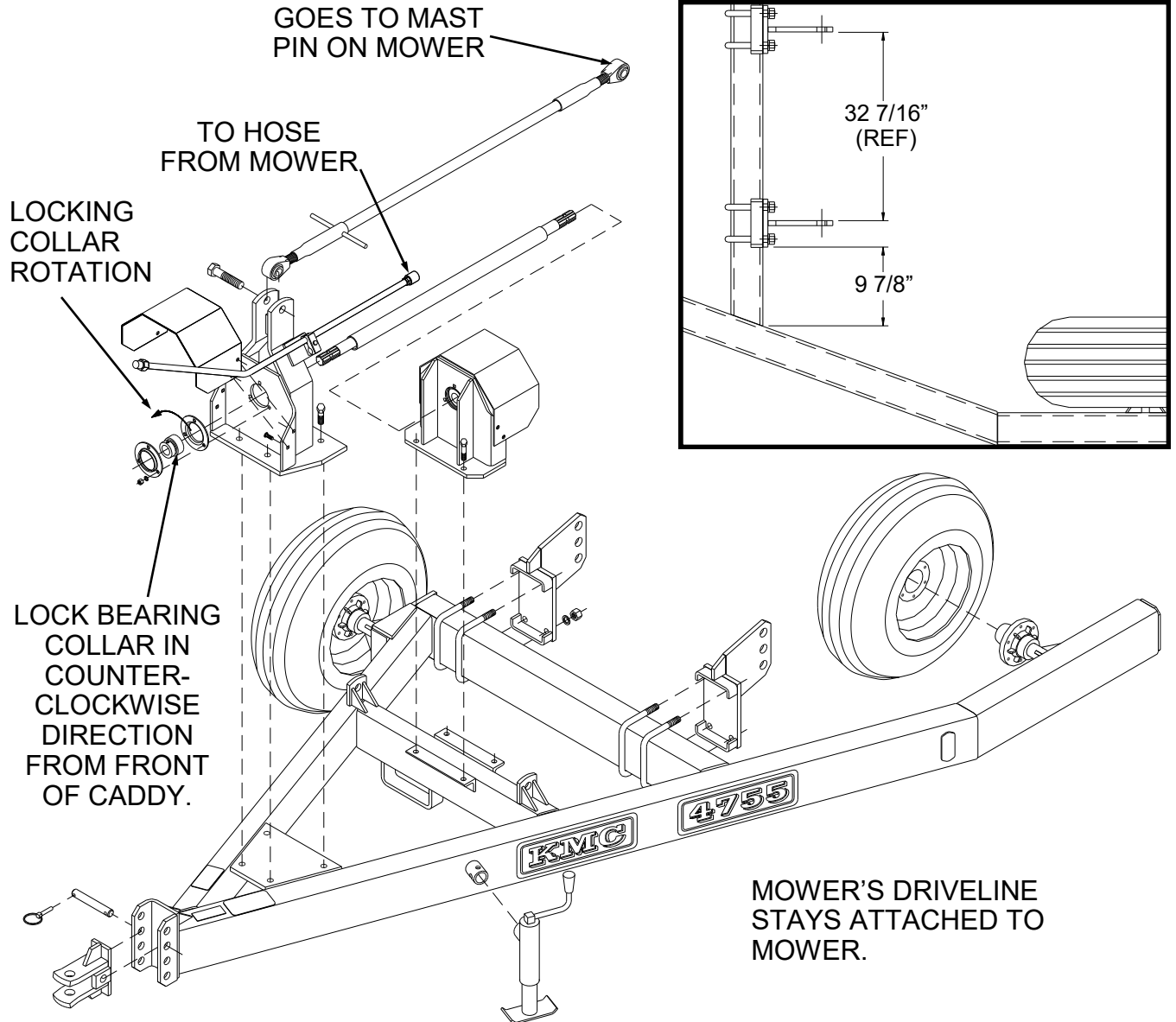

ASSEMBLED LOCATION OF JACKSHAFT

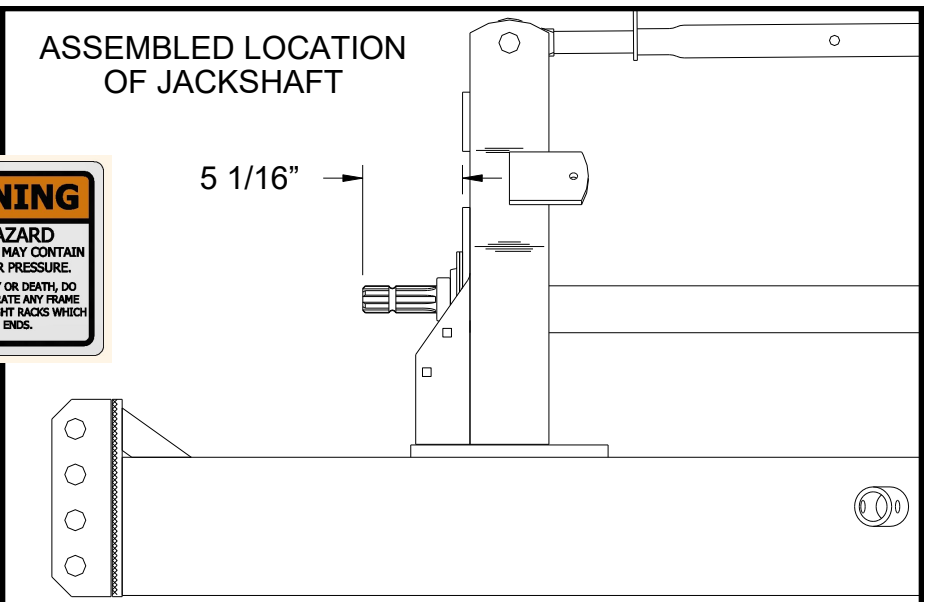

	WARNING
	<p>EXPLOSION HAZARD SEALED FRAME MEMBERS MAY CONTAIN FLAMMABLE GAS UNDER PRESSURE. TO PREVENT SERIOUS INJURY OR DEATH, DO NOT DRILL, WELD, OR PENETRATE ANY FRAME MEMBERS OR BALLASTED WEIGHT RACKS WHICH DO NOT HAVE OPEN ENDS.</p>

4760 SERIES

4760 CADDY (STD HITCH KIT)

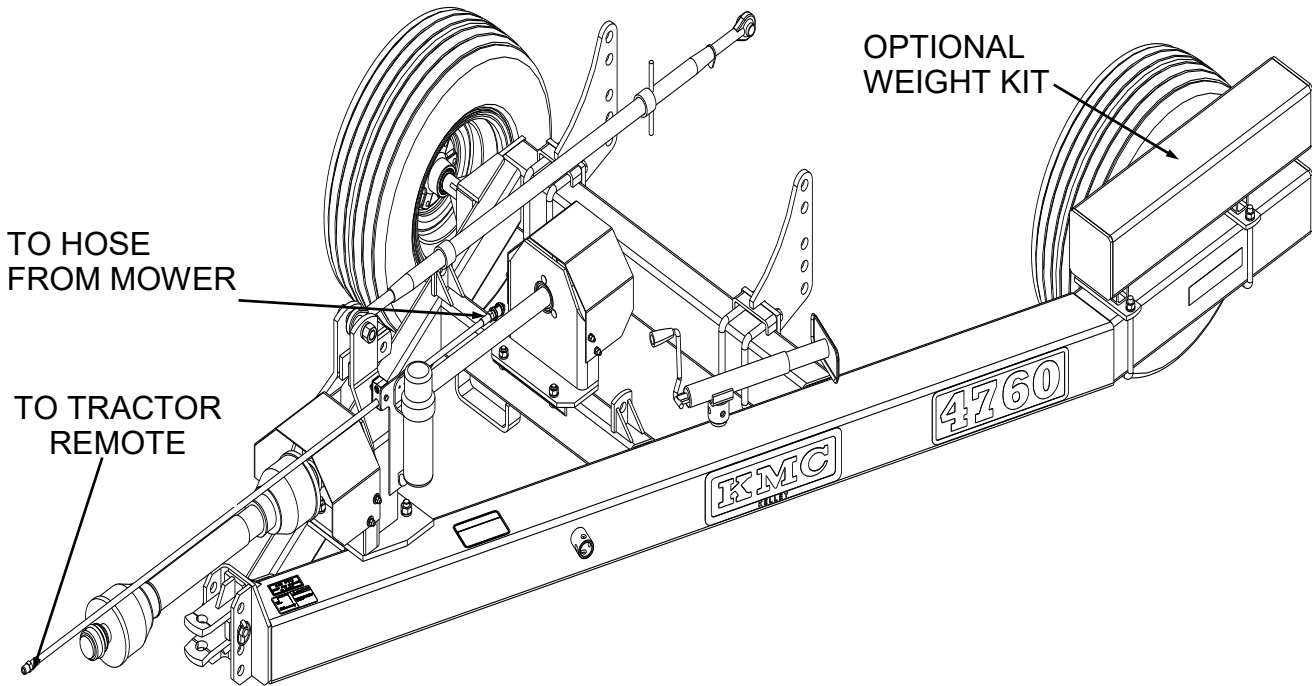

*REFER TO YOUR DISC MOWER
OWNER'S MANUAL FOR THE
CORRECT HITCH PIN HEIGHT.

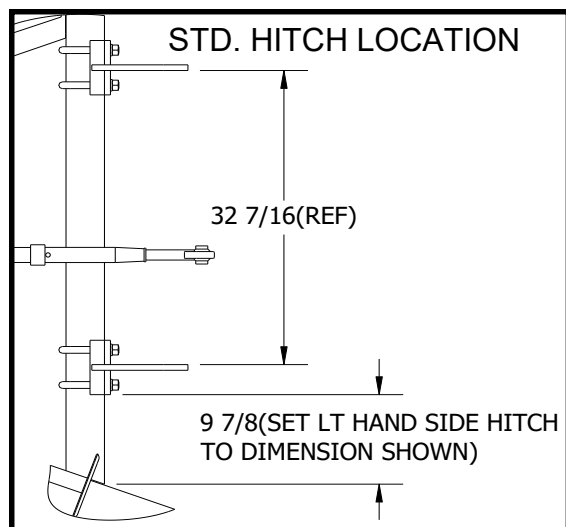
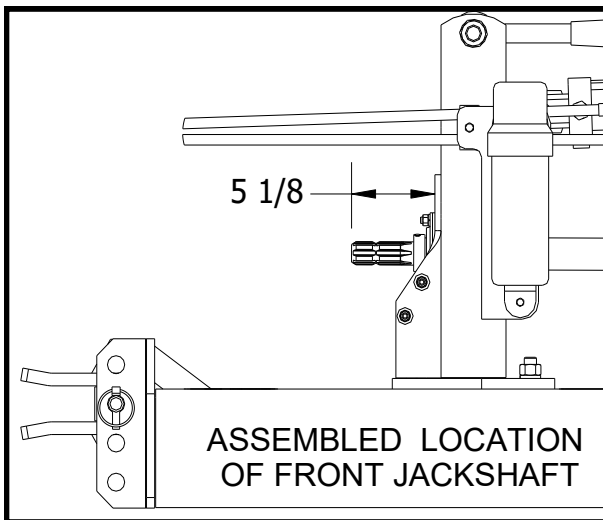

4760 CADDY (LIFT KIT)
(NOT FOR USE WITH CAT II QUICK HITCH MOWERS)

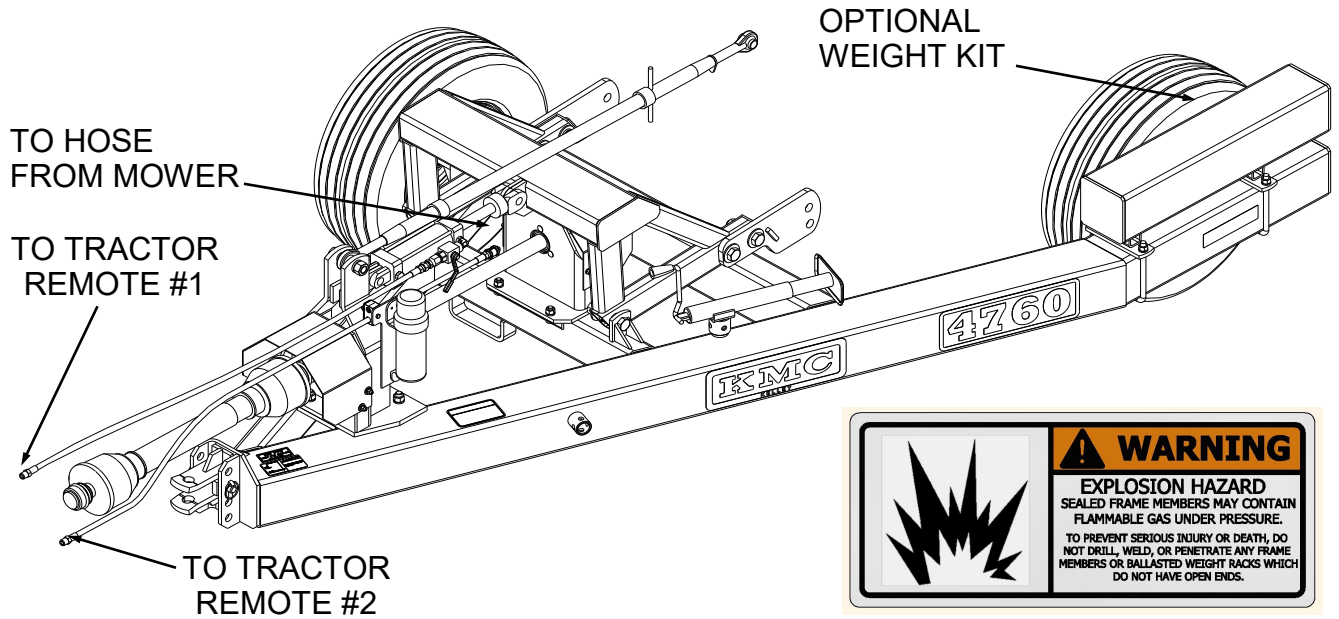

NOTE:
LIFT KIT VERSIONS OF THE DISC MOWER CADDY ARE NOT FOR USE WITH CAT II QUICK HITCH ONLY MOWERS. THEY ARE FOR USE WITH CAT II 3-POINT MOWERS, WHERE THE DISTANCE BETWEEN THE LOWER HITCH POINTS AND THE MAST POINT IS AT LEAST 19 INCHES.

Drawbar Position

The tractors drawbar should be positioned at a distance of 14 inches from the end of the PTO shaft to the drawbars hitch pin hole. (Standard distance for 540 PTO Drives)

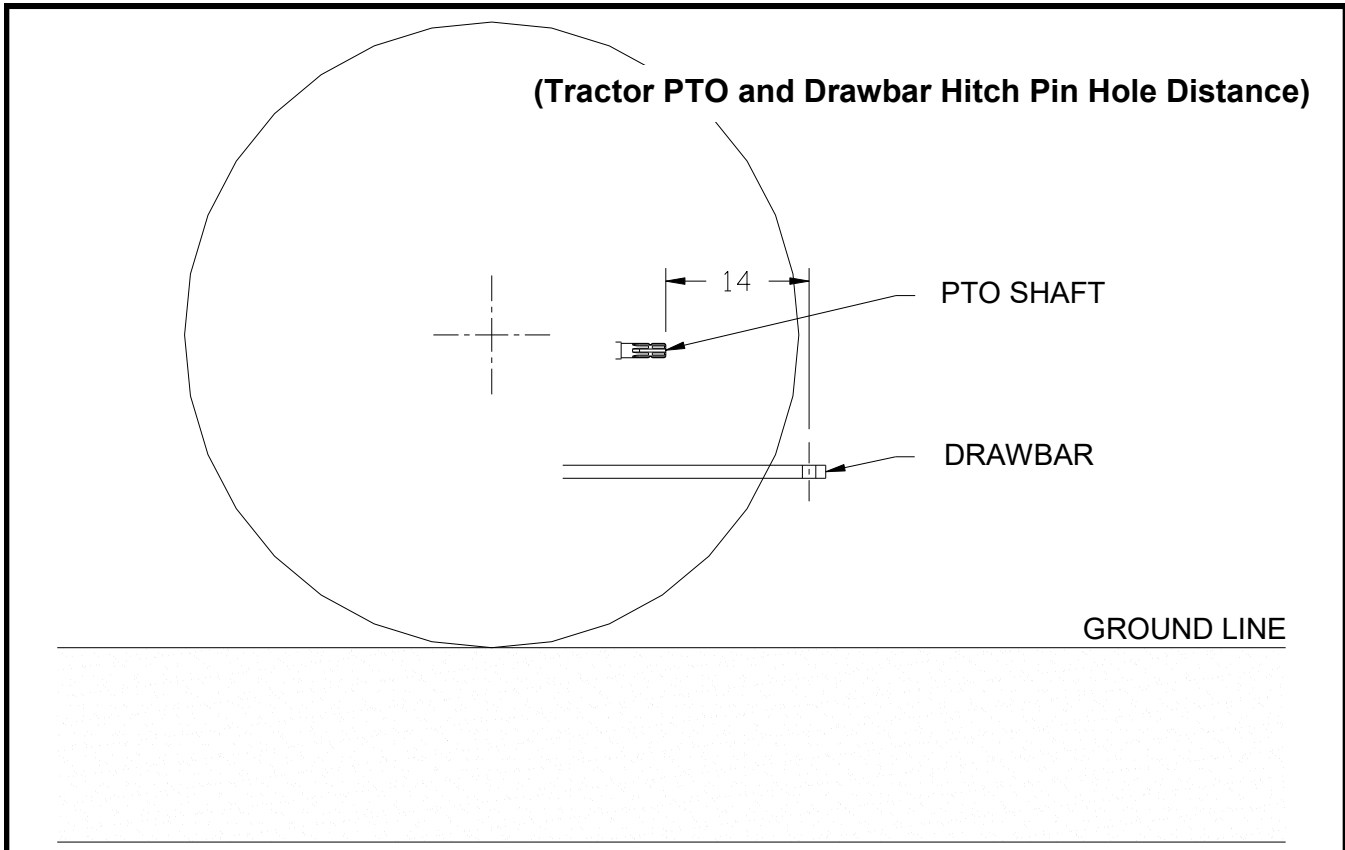

This distance will maintain the proper relationship for working driveline angles through turns and help improve the life of the driveline

Implement Hitch

This implements tongue/pull hitch is designed to give 4 different hitching positions.

In order for the Caddy to operate properly at all times, it is recommended that the proper hitch height be selected to keep the Main Frame and Caddy parallel with the ground. After drawbar and tongue/pull hitch are positioned correctly, the Tractor and Caddy can be hitched together.

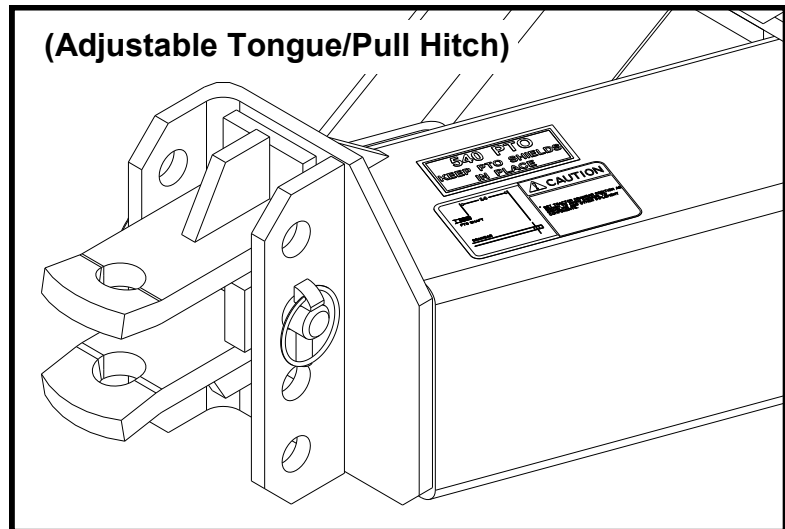

Mower Driveline (Model 4700 Only)

Due to the variation of distances between tractor PTO shafts and mower input shafts, the mowers driveline may need to be shortened to fit between tractor PTO and input on Caddy.

Before Shortening Driveline, Check Length in the following Way:

- With tractor hitched to Caddy, drive forward and turn tractor to the right until the maximum turning angle is achieved. Shut tractor off, leaving the caddy in this position. The tractor and Caddy are now positioned to give the shortest driveline distance.
- Fit the two “loose” half parts of the driveline on both the tractor and Caddy. Now, hold the half parts of the shaft together and check to determine the shortening length. If the driveline needs to be shortened, it should be cut to allow a 1” safety margin at the driveline’s closest collapsed length.



DRIVELINE MUST NOT BOTTOM OUT OR DAMAGE WILL OCCUR!!!

- Once shortening of the driveline is determined, the proper engagement, at the most extended position, must be checked. Drive forward with the tractor until Caddy and tractor are in line again. This is the drivelines most extended position. With half parts of driveline still attached to tractor PTO and Caddy input, hold shafts together again to ensure that the driveline halves will have an overlap of at least 6” after shortening.
- The driveline can now be shortened if necessary. (Consult your Mower’s Operating Manual for proper cutting procedure.)



GREASE DRIVELINE DAILY TO ENSURE PROPER OPERATION. IF DRIVELINE IS NOT GREASED PROPERLY SEVERE DAMAGE WILL OCCUR.

Mower Driveline (Model 4750, 4755 & 4760)

- The KMC supplied driveline with splined shaft goes between tractor and caddy. It should already be the correct length.
- The driveline that comes with the mower goes between the caddy and the mower. Consult the Mower’s Owners Manual if it needs modifying.

Positioning of Mower on Caddy

(ALWAYS MOUNT MOWER IN WORKING POSITION AND WITH CADDY HOOKED TO TRACTOR)

4700, 4750, 4755SH & 4760SH

Position mower’s cutter bar to allow clearance on outside of Caddy’s right wheel. Make sure that there is enough clearance to allow cutter bar to float freely. The left lower hitch mount on caddy has been preset at the factory to a distance that will likely work for mounting most mowers. (See Assembly Instructions) Should this position not work, both lower hitch mount are fully adjustable. It should be noted also, that most newer mowers will slide left to right on their lower hitch pins. (See Mower Manual) This can be used to position

4755LK & 4760LK

The position of the mower on the caddy is already predetermined when using the lift kit version of model 4755 and 4760. Should there be clearance problems with this position, most newer mowers will slide left or right on their lower hitch pins. (See Mower Manual)

Attaching Mower

FOR 4700, 4750, & 4755SH

Once positioning of the mower has been determined and the Caddy's left lower hitch mount has been bolted in position, the mower can be attached to the Caddy.

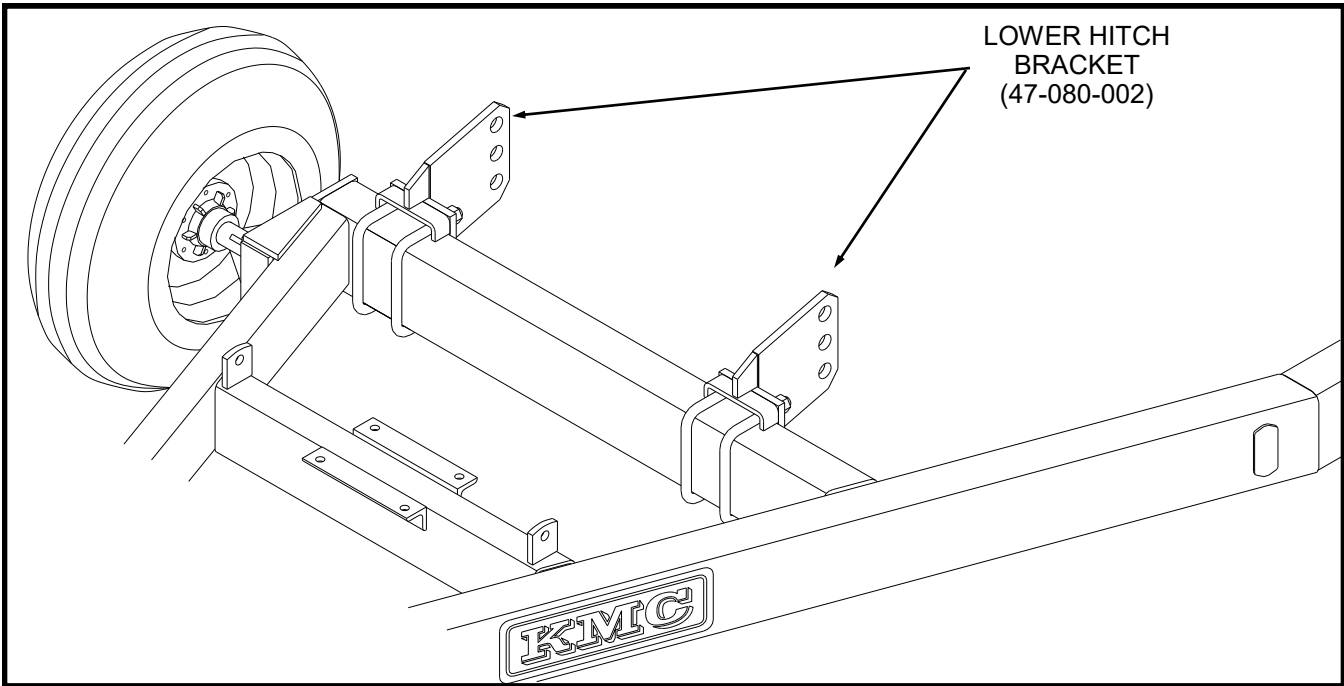

FOR 4760SH

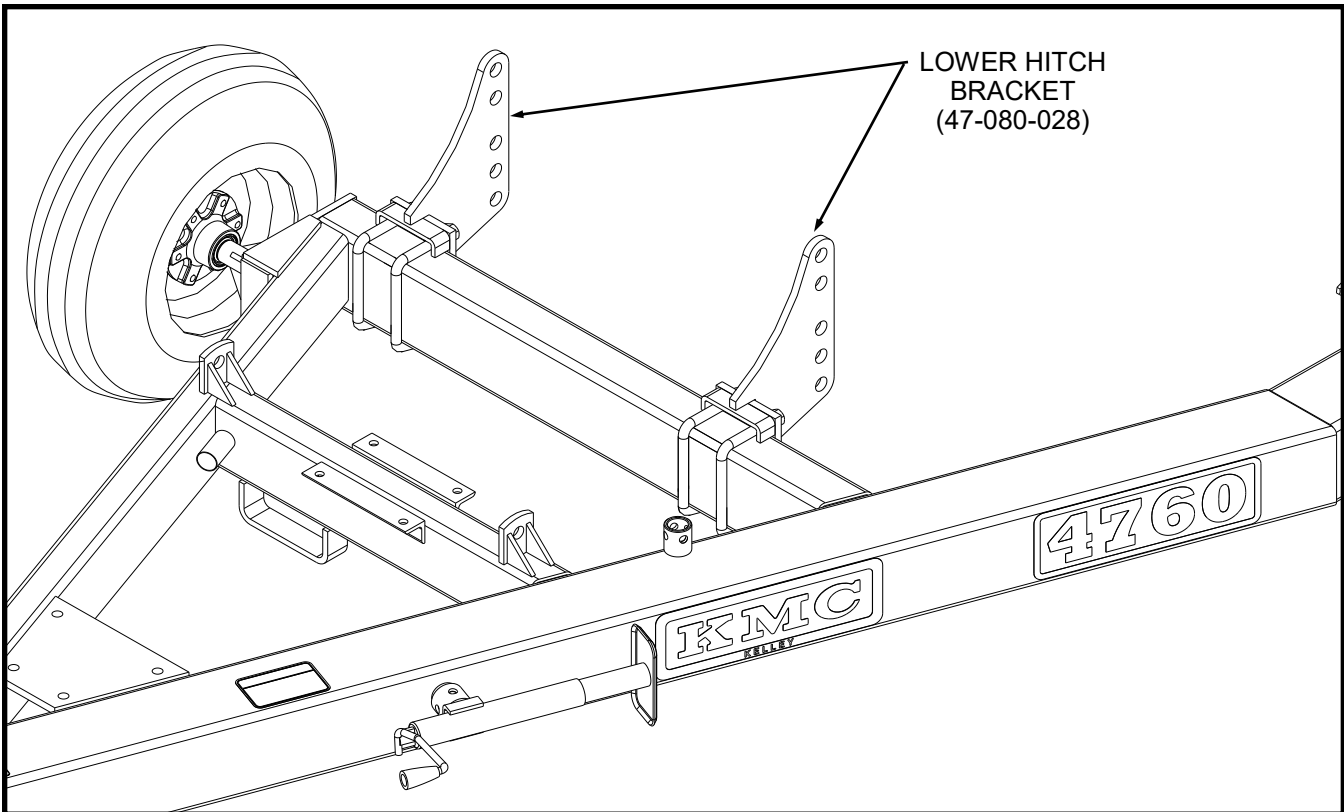

The Caddy's lower hitch mounts are designed with 3 different height positions. These 3 different height positions ensure that the mower can be mounted to have equal float of the mower's cutter bar. Depending on the weight of the mower and tire pressure, most mowers will likely utilize the 2 lower holes. To determine exactly what height to mount the mower, it is suggested that the Mower's Owner Manual be reviewed. If a higher hitch point is required, (47-082-009) or (47-082-013) Lower Hitch Extension Kits are available.

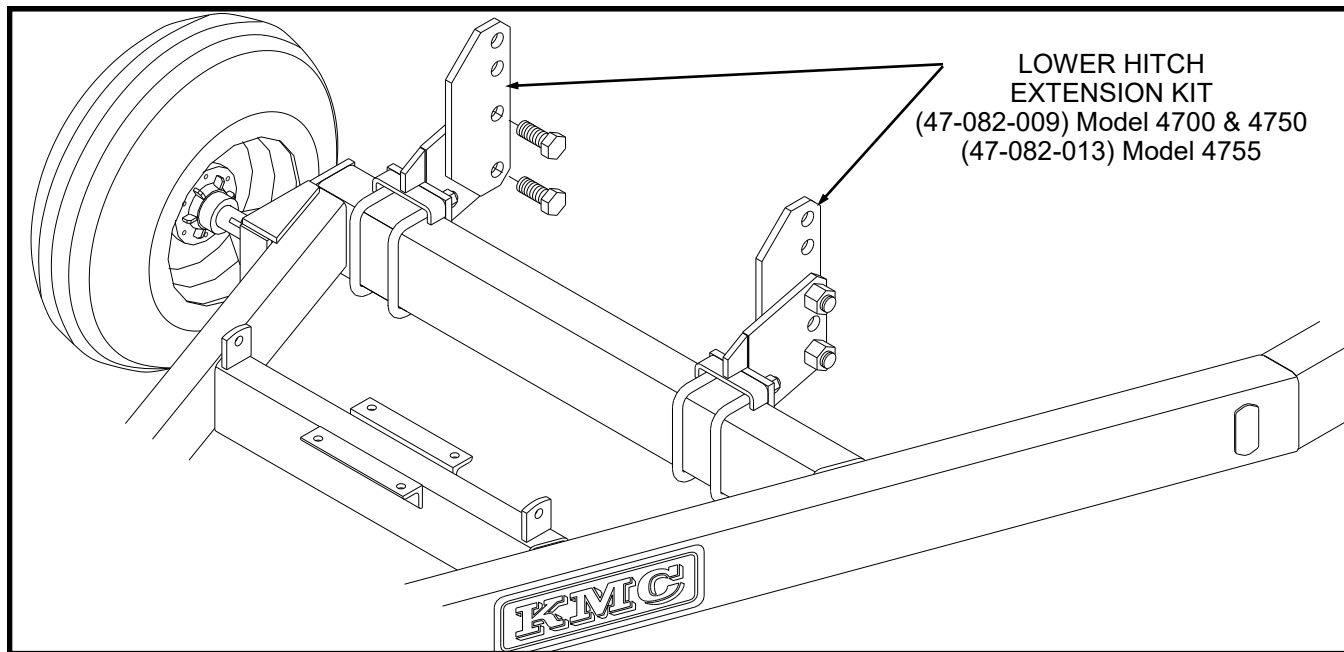

ALL MODELS

The mower can now be lifted and the left hand pin can be angled into the correct position of the left lower hitch mount. The mower can then be swung into place and the right lower hitch mount can be slid onto the mower's right hand pin and bolted in place (See Figure 4 or Figure 4A for 4755ILK)

Once the mower is safely mounted in the Caddy's Lower Hitch Mounts, the top link and 2 x 8 Cylinder (for 4750 or 4755 Lift Kit Models) & 3 X 6 Cylinder (for 4760 Lift Kit Models) should be attached.

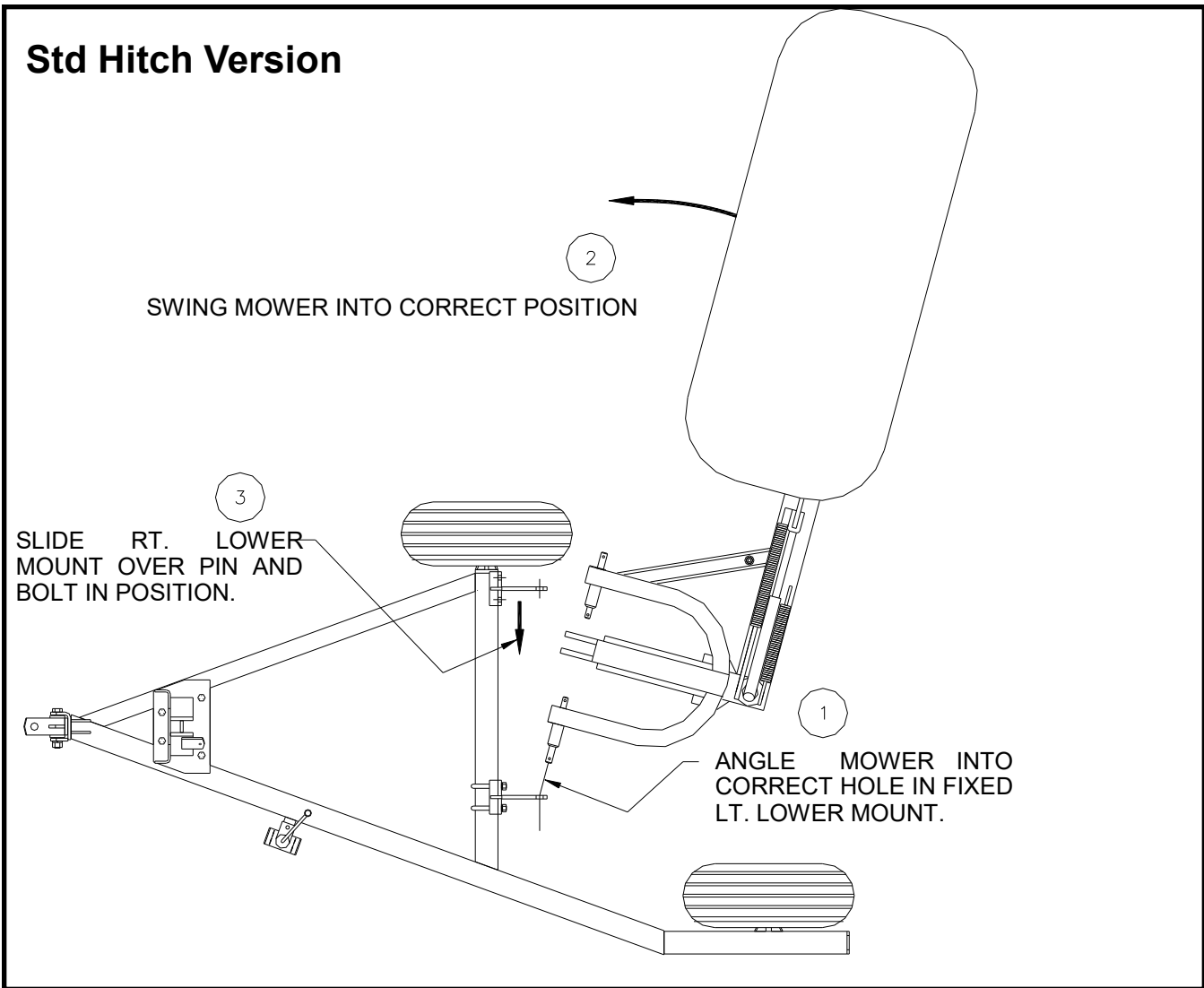

NOTE: When attaching the Caddy's top link, make sure that both ends of the turnbuckle have the same amount of threads showing. This will ensure that the top links full adjustment can be used.

The mower should now be secure and can be released from the lifting device.

Lift Kit Version

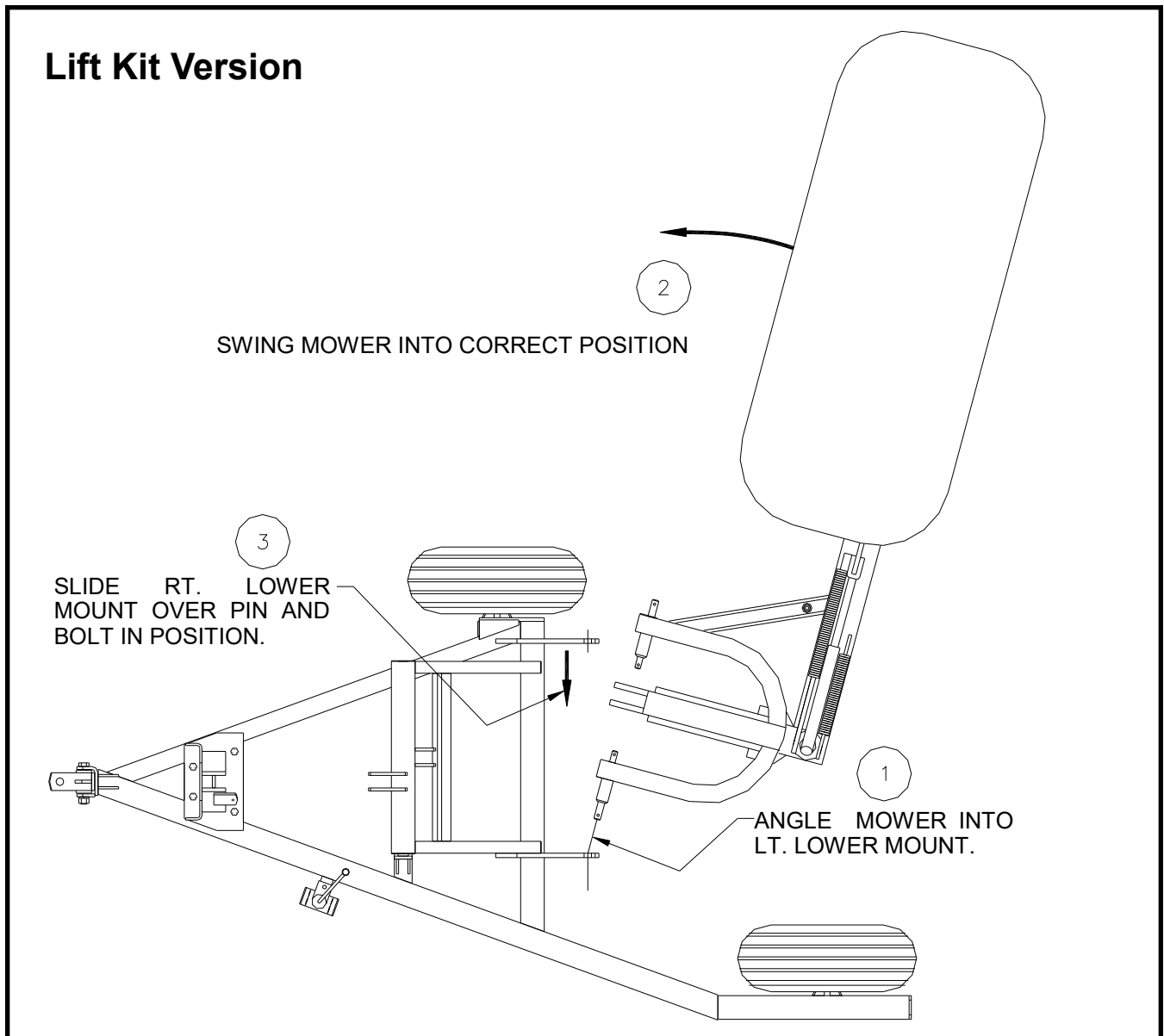

Adjusting Angle of Mower

To adjust the angle of the mower simply screw the top link in or out. To aid in this process a pull bar can be slid over the existing handle and utilized for leverage. To ensure that the mower is operating at its most efficient angle, consult the Mower's Owner Manual.

Miscellaneous

Some mowers have locking mechanisms which secure the mower during transport. These same mowers also have pull cords that the driver can use from the tractor cab to unlock the mower from transport position. When the caddy is used, these cords will have to be lengthened to have access from the tractor cab. For Model 4755LK, route pull cord thru transport latch arm.

NOTE: Certain Krone Easycut Mowers have a safety trip arm. On these mowers it is required to slide the hitch pin shaft over to provide clearance for the arm to trip and swing forward.

Before Operation

- Hook Caddy's Driveline to input shaft on mower. (4700 Series)
- Hook Mowers Driveline from splined shaft on caddy to mower's input shaft, (4750, 4755 & 4760 Series)
- Connect the hydraulic hose for raising and lowering cutter bar to a single or double acting valve on tractor. Engage hydraulics to

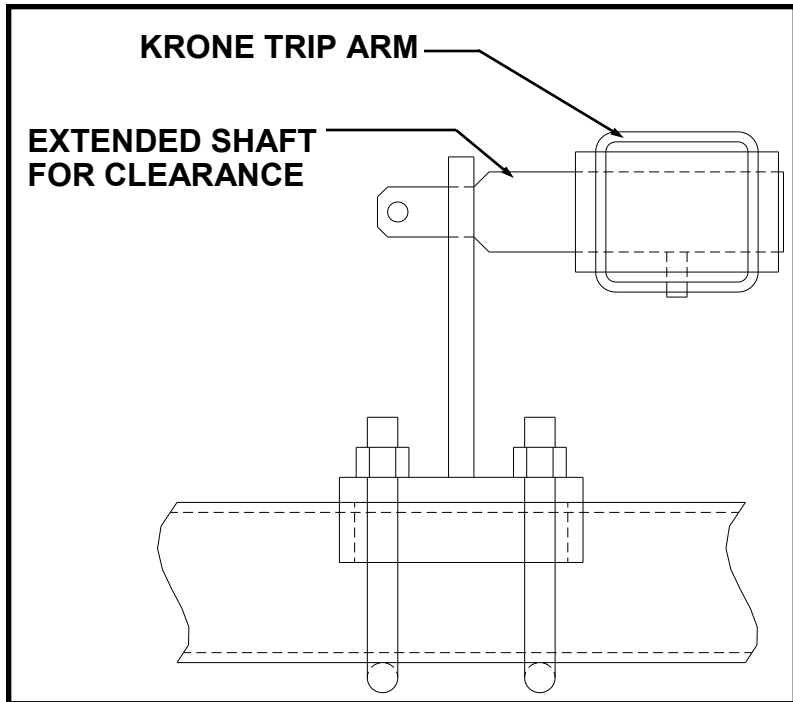

check for proper operation (Also see Mower's Owners Manual before operating hydraulics).

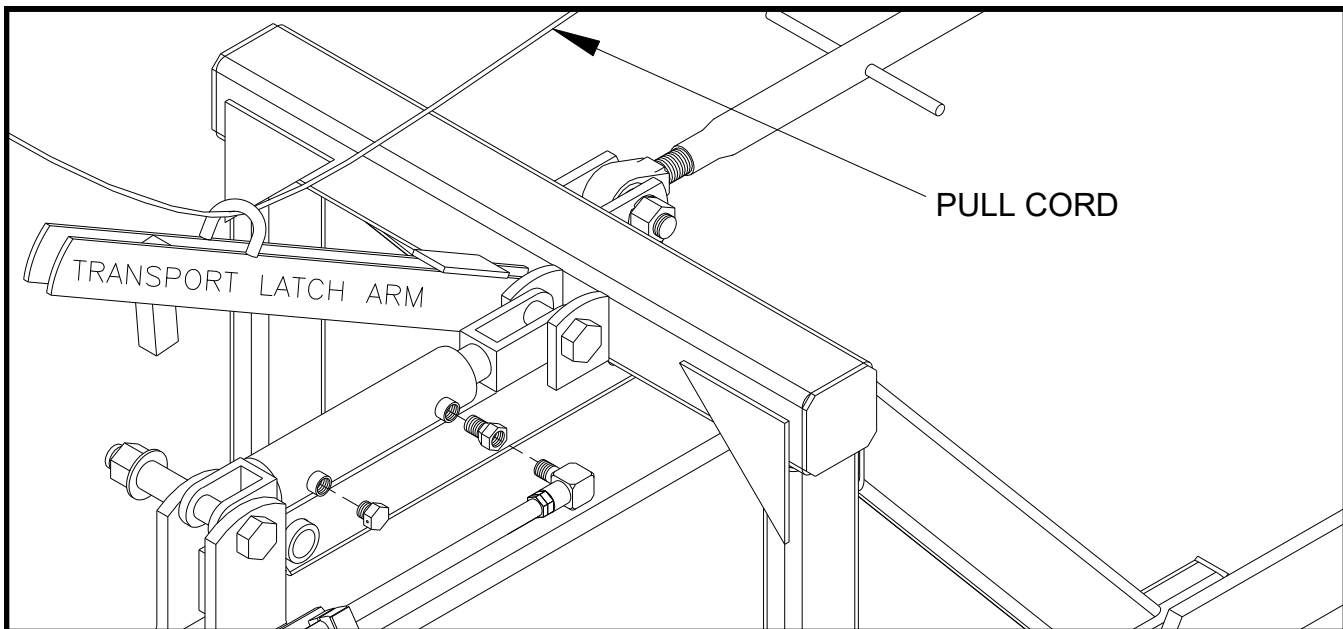

CAUTION

WHEN FOLDING AND UNFOLDING MOWER'S CUTTER BAR, ALWAYS HAVE CADDY HITCHED TO TRACTOR. FAILURE TO DO SO COULD RESULT IN DAMAGE TO IMPLEMENT OR POSSIBLE PERSONAL INJURY.

- Check for proper assembly and adjustment. Make sure that all bolts are tightened. Securely retighten all bolts after a few hours of operation as bolts can loosen up on new machinery. Check wheel bolts upon delivery and periodically thereafter. Wheel bolts should be tightened at 85-95 ft/lbs of torque.
- Check tires and inflate to recommended pressure (28 PSI cold for 6-ply, up to 44 PSI for 10 ply).
- Make sure that drivelines and bearings are lubricated completely.

OPERATIONAL SETUP

- Operating speed for Caddy components and mower is 540 RPM.
- Ground speed may be determined by many factors, the density and humidity of the forage and the composition or type of forage to be cut. It is recommended that the mower manufacturer's instructions be followed for determining ground speed.



CAUTION

WHEN MAKING A LOOP AT THE END OF A PASS TO SQUARE OFF THE CORNERS OF A FIELD, ONLY LIFT THE CUTTER BAR SLIGHTLY THRU THE TURN. LIFTING THE CUTTER BAR HIGH OFF THE GROUND IN OPERATION WILL CAUSE THE GEARS ON THE END OF THE BAR TO BECOME STARVED FOR OIL. KMC WILL NOT BE RESPONSIBLE FOR ANY DAMAGE CAUSED BY THE ACTION OF LIFTING THE CUTTER BAR DURING OPERATION.

- Always operate this or any machine with the greatest care taken for your safety and the safety of all bystanders.

MAINTENANCE

- Regularly check bolts for tightness, especially during the first few hours of use.



CAUTION

NEVER PERFORM MAINTENANCE OR ADJUSTMENTS TO THE MACHINE WHILE THE TRACTOR IS RUNNING. ALLOW ALL MECHANISMS TO STOP COMPLETELY BEFORE CLEANING, WORKING OR ADJUSTING ON MACHINE.

SERVICE SCHEDULE

The **KMC Disc Mower Caddy** has been carefully designed and manufactured to provide years of dependable service. To maximize use and reduce downtime and repair costs, regular maintenance should be performed on the Disc Mower Caddy. Below is a guide for minimum recommended services and the time intervals for their completion. However, since these machines are used in many different conditions and applications, the operator should customize the maintenance schedule to best fit their individual needs.

	SERVICE	EVERY 10 HOURS	EVERY 50 HOURS	EVERY 250 HOURS
1	LUBRICATE ALL GREASE POINTS (see Lubrication Points in the Maintenance section of this manual)	X		
2	CHECK TORQUE ON ALL BOLTS (See Bolt Torque Chart in Section on General Assembly Set-up)	X		
3	INSPECT HITCH PINS FOR WEAR		X	
4	INSPECT BEARINGS		X	
5	INSPECT TIRE PRESSURE IN ALL GAUGE AND PRESS WHEELS	X		

LUBRICATION POINTS

- Grease all drivelines and bearings daily to ensure proper operation.

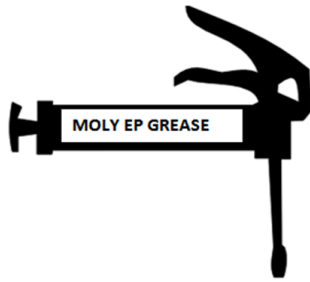

TRANSPORTATION

- Use **CAUTION** when towing the caddy without a mower attached. There is very little weight on the front right tire. The caddy can tip over to the left during a sharp or fast right hand turn. Use ballast on the right side or tighten up the hitch pin fit to prevent roll-over.
- **NEVER** transport caddy with optional weight rack mounted without a mower attached.
- When transporting the Caddy with mower attached, be aware that on the right side of tractor, the mower will extend beyond the tractor tires. Care should be taken not to hang the mower on any objects as this could result in serious damage.

STORAGE



CAUTION

Always store mower, when hooked to Caddy, with cutter bar resting on the ground. Windy conditions could cause the Caddy to flip backwards when mower is left in raised position.

The following is a list of serial numbers issued to our implements at the beginning of each year. To determine when a unit was made, find the range in which the particular serial number falls. The implement would have been produced between January 1st to December 31st of that year.

YEAR	SERIAL NUMBERS
1985	27986-29695
1986	29696-31095
1987	31096-33234
1988	33235-35548
1989	35549-38496
1990	38497-41771
1991	41772-44466
1992	44467-47001
1993	47002-48750
1994	48751-51549
1995	51551-54262
1996	54263-56661
1997	56662-59465
1998	59466-62097
1999	62098-63986
2000	63987-65692
2001	65693-67340
2002	67341-68699
2003	68700-70482
2004	70483-72646
2005	72647-74866
2006	74867-76368
2007	76369-77883
2008	77884-79891
2009	79892-80944
2010	80945-81775
2011	81776-83453
2012	83454-85092
2013	85093-86418
2014	86419-87790
2015	87791-89096
2016	89097-89924
2017	89925-91270
2018	91271-92260
2019	92261-



DEPENDABLE EQUIPMENT FOR PROGRESSIVE FARMING

Visit us at www.kelleymfg.com



KELLEY MANUFACTURING CO.

80 Vernon Drive / Zip 31794
P.O. Drawer 1467 / Zip 31793
Tifton, GA



Tel: 229-382-9393
Toll Free: 1-800-444-5449
Fax: 229-382-5259

Email Address: info@kelleymfg.com